

An Investigation of Structural Vibration on Main Oil Line Pump at Tiong-A Platform, Offshore Kerteh, Terengganu, 2000

Frequent failure of the MOL Pumps unit A, B & C at Tiong-A Platform, Offshore Kerteh, Terengganu is investigated. Analysis techniques included Operating Deflection Shape Analysis, Modal Analysis and Finite Element Analysis.

From Modal analysis and Finite Element analysis on the GE Motor and the US Motor, it is concluded that the natural frequency of GE Motor at 56 Hz (second bending mode) was the root cause of the frequent failure. The US Motor was having a higher natural frequency of the second bending mode at 73 Hz – which is sufficiently away from the running speed (60Hz). Thus, the US Motor does not suffer from resonance problem.

Operating Deflection Shape analysis confirms that at the running speed, the structural motion is being dominated by the second bending mode.

It is strongly recommended that for the GE Motor to be utilized, structural dynamic modification had to be performed on the discharge head to shift the natural frequency of the second bending mode away from the running speed. This modification on the discharge head shall only be used with GE Motor. The structural dynamic modification is performed using Finite Element Analysis and the detail engineering drawings are attached for further actions. The modification is performed using six 2.54cm thick ribs being welded to the bottom of the discharge head column and the ring at an angle of 74.5°. The 2.54cm thick ribs has shifted the second bending mode from 56.6 Hz to 97.3Hz which is already far from the running speed without disturbing the twisting mode natural frequency at 31Hz.

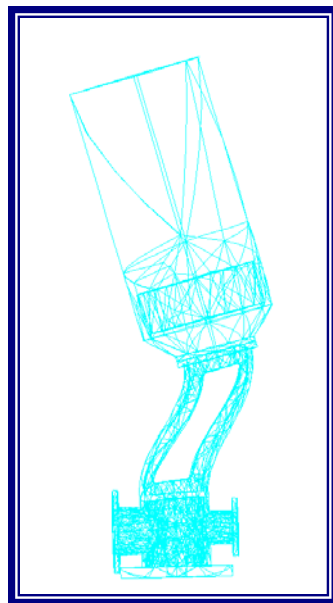

FEA Result of MOL pump with GE Motor @ 56.6Hz – 2nd Bending Mode

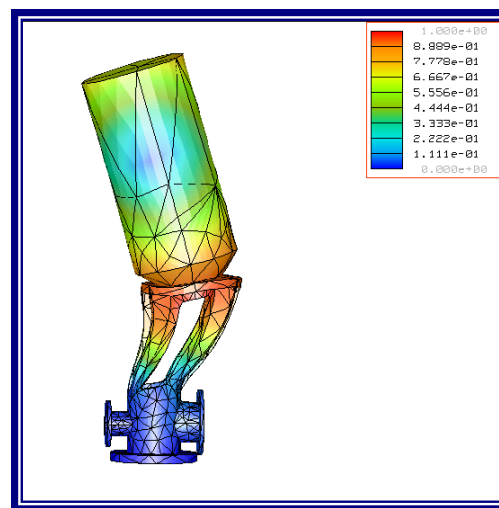

FEA Result of Modified MOL pump assembly with GE Motor @ 97.3Hz– 2nd Bending Mode